



**Technical Specifications and
Clearance Information for
MR Conditional EEG Electrodes**

With the growth of the use of MR technology, the U.S. Food & Drug Administration [FDA] recognized the need for a consensus on standards of practice, and the FDA sought out ASTM International [ASTM] to achieve them. Working with key stakeholders, Committee FO4 of ASTM developed F2503, Practice for Marking Medical Devices and Other Items for Safety in the Magnetic Resonance Environment. These practices have been put in place for RhythmLink's MR Conditional/CT electrodes.

RhythmLink's MR Conditional/CT Electrodes have been cleared by the FDA and have demonstrated to be both safe and effective for their intended use. These electrodes can remain safely on the patient during MR imaging under specific conditions. Our Slim Cup™, Deep Cup™, Webb™ Sticky Pad™ and PressOn™ MR Conditional/CT Electrodes incorporate a proprietary design which has undergone extensive computer simulations and real world testing to assess its safety and efficacy in numerous scenarios including presenting patient conditions, staffing challenges and even unplanned emergency care.

Please consult our most current product labeling and IFU documents for full product details.

New Safety Information for 2025 Added risk of multi-lead arrays longer than 245mm

Radiology has the responsibility to ensure patient and medical staff safety in the MRI environment, in accordance with device IFUs and real-world application. The MR environment poses unique challenges due to the many factors that impact the risk of a medical device (e.g. characteristics of each machine's static magnetic field, gradient magnetic fields, radiofrequency [RF] coils).

With the use of EEG Electrodes, one particular concern is RF induced heating, which can induce heating of the adjacent tissue or the device itself, resulting in thermal damage or burns if not used to exact specifications. **Additional testing conducted by RhythmLink found added risk associated with the use of electrodes over 250mm in length in nonstandard configurations. The added length of lead wires extending from the EEG cup to the MR connector generate heat well beyond 4° C in certain configurations and pose risk to patient safety.** Scan the QR code to see a comprehensive report of RhythmLink's findings in additional detail.

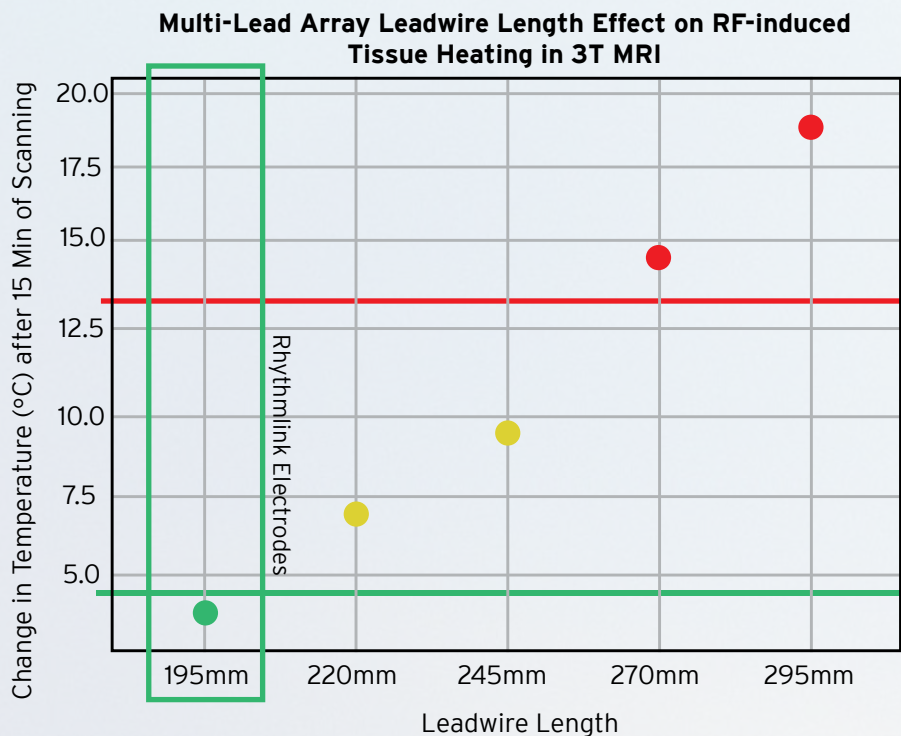

Irreversible tissue damage at 13° C

FDA threshold for up to 60 min of scanning without cool-down periods, 4° C (7.2° F)

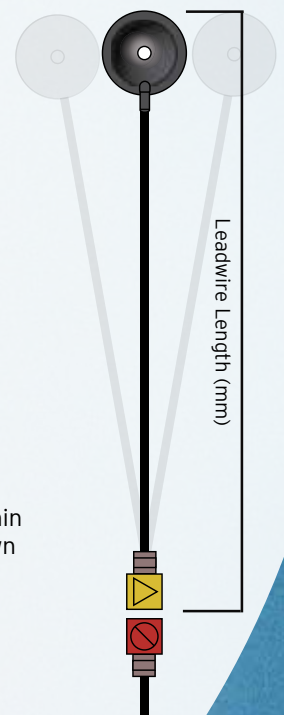

MR Conditional/CT Quick Connect System™

Slim Cup, Deep Cup and Webb Electrodes or Combination

Intended Use

The MR Conditional/CT Cup and Webb Electrodes are intended for use in the recording of the Electroencephalography [EEG], Evoked Potentials [EP] or as a Ground or Reference in an EEG or EP recording. This device is non-sterile for Single Patient Use Only and may remain on the patient in a MRI environment under specific conditions.

Caution

Federal [USA] law restricts this device to sale by or on the order of a physician and it should only be used in compliance with accepted industry standards. Rhythmink International, LLC is not responsible for injury, infection or other damage resulting from the use or misuse of this product.

MR Conditional/CT Cup and Webb Electrodes are for professional use only and should only be used in compliance with accepted industry standards. **The included extension cables [Fig. 1] are MR Unsafe.** Remove all extension cables before entering a MR environment.

Instructions for Use

Clean application site. Apply electrode using Weaver Ten20 conductive paste. MR Conditional/CT Cup and Webb Electrodes are only approved for use with Weaver Ten20 conductive paste. Collodion may be used if desired. At least two (2) electrodes, per array, must be applied to the patient for use in the MR environment. Remaining electrodes can either be left unattached or can be removed by cutting the electrode wire flush to the connector. Remove all extension cables before entering an MR environment. When finished, remove electrodes and clean application sites.

MRI Safety Information

Non-clinical testing has demonstrated that the MR Conditional/CT Cup and Webb Electrodes Array [Fig. 2] is MR Conditional in configurations of 2 to 40 electrodes, using 1 to 4 arrays. These electrodes can safely remain on a patient during a MR scan meeting the following conditions:

Parameter	Condition of Use/Information
Device Name	Rhythmink MR Conditional/CT EEG Electrodes
Static Magnetic Field Strength (Bo)	0.2T, 0.5T, 1T, 1.5T, 3T
Static Magnetic Field Strength (Bo) Orientation	Horizontal, cylindrical bore
Maximum Spatial Field Gradient	40 T/m (4,000 gauss/cm)
RF Polarization	Circular Polarized (CP)
RF Transmit Coil	Integrated Whole Body Transmit RF Coil
RF Receive Coil	Any Receive coil may be used
MR System (RF) Operating Modes or Constraints	Normal Operating Mode
Maximum Head SAR	3.2 W/kg (Normal Operating Mode)
Maximum Whole-Body SAR	2.0 W/kg (Normal Operating Mode)
Scan Duration	15 minutes of continuous RF (a sequence or back to back series/scan without breaks)
MR Image Artifact	The presence of Rhythmink MR Conditional/CT EEG Electrodes may produce an image artifact. Some manipulation of scan parameters may be needed to compensate for the artifact.

Under the scan conditions defined in this chart, the MR Conditional/CT Cup and Webb Electrodes are expected to produce a maximum temperature rise of 4°C or less after 15 minutes of continuous scanning.

In non-clinical testing, the image artifact caused by the device extends less than 2.5 mm from the MR Conditional/CT Cup and Webb Electrodes when imaged with a gradient echo pulse sequence and a 3.0 Tesla MRI system.

The MR Conditional/CT Cup and Webb Electrodes have not been tested in simultaneous combination with other devices.

Artifact Information

MR image quality may be compromised if the area of interest is in the same area or relatively close to the position of the device. Therefore, it may be necessary to optimize MR imaging parameters for the presence of this device.

MR image artifacts can affect the device surrounding on each side from the device surface as follows:

Non-Clinical Artifact Testing at 3T	Spin Echo	Gradient Echo
Test object length	1.46 mm	2.11 mm
Test object diameter	2.22 mm	2.46 mm

The included extension cables are MR Unsafe. Remove all extension cables before entering an MR environment.

Avoid prolonged or repeated exposure to substances containing acetone or ethyl acetate. These solvents can damage the electrode and may lead to premature product failure.

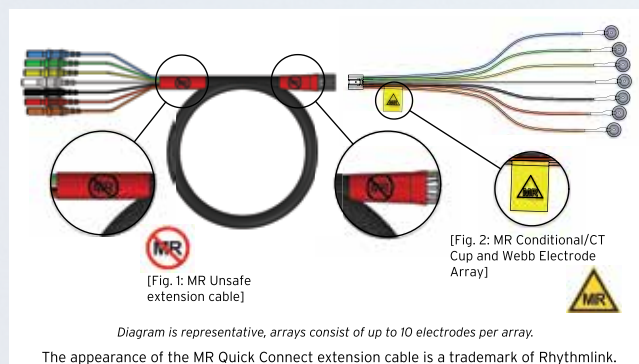

Please consult our most current product labeling and IFU documents for full product details.

MR Conditional/CT Individual Connectors Slim Cup, Deep Cup and Webb Electrodes or Combination

Intended Use

The MR Conditional/CT Disposable EEG Cup or Webb Electrode is intended for use in the recording of the Electroencephalography [EEG], Evoked Potentials [EP] or as a Ground or Reference in an EEG or EP recording. This device is provided non-sterile for Single Patient Use Only and may remain on the patient in a MR environment under specific conditions.

Caution

Federal [USA] law restricts this device to sale by or on the order of a physician and it should only be used in compliance with accepted industry standards. Rhythmink International, LLC is not responsible for injury, infection or other damage resulting from the use or misuse of this product.

MR Conditional/CT Disposable Cup and Webb Electrodes are for professional use only and should only be used in compliance with accepted industry standards. **The included extension cables [Fig. 1] are MR Unsafe.** Remove all extension cables before entering a MR environment.

Instructions for Use

Clean application site. Apply Electrode using Weaver Ten20 conductive paste. MR Conditional/CT Disposable Slim EEG Cup Electrodes are only approved for use with Weaver Ten20 conductive paste. Collodion may be used if desired. Remove all extension cables before entering an MR environment. When finished, remove electrodes and clean application sites.

MRI Safety Information

Non-clinical testing has demonstrated that the MR Conditional/CT Disposable Slim Cup, Deep Cup and Webb EEG Electrode [Fig. 2] is MR Conditional in configurations of 2 to 48 electrodes. These electrodes can safely remain on a patient during an MR scan meeting the following conditions:

Parameter	Condition of Use/Information
Device Name	Rhythmink MR Conditional/CT EEG Electrodes
Static Magnetic Field Strength (Bo)	0.2T, 0.5T, 1T, 1.5T, 3T
Static Magnetic Field Strength (Bo) Orientation	Horizontal, cylindrical bore
Maximum Spatial Field Gradient	40 T/m (4,000 gauss/cm)
RF Polarization	Circular Polarized (CP)
RF Transmit Coil	Integrated Whole Body Transmit RF Coil
RF Receive Coil	Any Receive coil may be used
MR System (RF) Operating Modes or Constraints	Normal Operating Mode
Maximum Whole-Body SAR	2.0 W/kg (Normal Operating Mode)
Scan Duration	15 minutes of continuous RF (a sequence or back to back series/scan without breaks)
MR Image Artifact	The presence of Rhythmink MR Conditional/CT EEG Electrodes may produce an image artifact. Some manipulation of scan parameters may be needed to compensate for the artifact.

Remove extension cables [Fig. 1] before entering an MR environment They are MR Unsafe.

Under the scan conditions defined above, the MR Conditional/CT Disposable Webb EEG Electrode is expected to produce a maximum temperature rise of less than 2°C after 15 minutes of continuous scanning.

In non-clinical testing, the image artifact caused by the Webb Electrode extends less than:

2 mm from the Slim Cup Electrode when imaged with a gradient echo pulse sequence and a 3T MRI system;

4mm from the Deep Cup Electrode when imaged with a gradient pulse sequence and a 3T MRI system;

3 mm from the Webb Electrode when imaged with a gradient echo pulse sequence and a 3T MRI system.

The MR Conditional/CT Disposable EEG Webb Electrode, dual and multiple configurations [2 to 48 electrodes] have not been tested in simultaneous combination with other devices.

The included extension cables are MR Unsafe. Remove all extension cables before entering an MR environment.

Avoid prolonged or repeated exposure to substances containing acetone or ethyl acetate. These solvents can damage the electrode and may lead to premature product failure.

Artifact Information

MR image quality may be compromised if the area of interest is in the same area or relatively close to the position of the device. Therefore, it may not be necessary to optimize MR imaging parameters for the

presence of this device. MR image artifacts can affect the device surrounding on each side from the device surface as follows:

Slim Cup EEG Electrode

Non-Clinical Artifact Testing at 3T	Spin Echo	Gradient Echo
Test object length	0.43 mm	0.90 mm
Test object diameter	1.39 mm	1.47 mm

Deep Cup EEG Electrode

Non-Clinical Artifact Testing at 3T	Spin Echo	Gradient Echo
Test object length	1.78 mm	2.99 mm
Test object diameter	1.77 mm	3.55 mm

Webb EEG Electrode

Non-Clinical Artifact Testing at 3T	Spin Echo	Gradient Echo
Test object length	0.72 mm	1.50 mm
Test object diameter	2.05 mm	2.40 mm

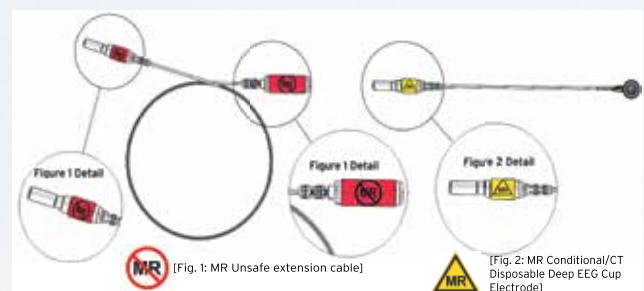

Please consult our most current product labeling and IFU documents for full product details.

MR Conditional/CT Individual Connectors PressOn™ Electrodes

Intended Use

The MR Conditional/CT PressOn Electrode is intended for use in the recording of the Electroencephalography [EEG], Evoked Potentials [EP] or as a Ground or Reference in an EEP or EP recording. This device is provided sterile for Single Patient Use Only and may remain on the patient in a MR environment under specific conditions.

Caution

Federal [USA] law restricts this device to sale by or on the order of a physician and it should only be used in compliance with accepted industry standards. Rhythmink International, LLC is not responsible for injury, infection or other damage resulting from the use or misuse of this product.

MR Conditional/CT PressOn Electrodes are for professional use only and should only be used in compliance with accepted industry standards. **The included extension cables [Fig. 1] are MR Unsafe.** Remove all extension cables before entering a MR environment.

MR Safety Information

Non-clinical testing has demonstrated that the MR Conditional/CT Disposable PressOn Electrode [Fig. 2] is MR Conditional in configurations of 2 to 48 electrodes. These electrodes can safely remain on a patient during an MR scan meeting the following conditions:

Parameter	Condition of Use/Information
Device Name	Rhythmink MR Conditional/CT EEG Electrodes
Static Magnetic Field Strength (Bo)	0.2T, 0.5T, 1T, 1.5T, 3T
Static Magnetic Field Strength (Bo) Orientation	Horizontal, cylindrical bore
Maximum Spatial Field Gradient	40 T/m (4,000 gauss/cm)
RF Polarization	Circular Polarized (CP)
RF Transmit Coil	Integrated Whole Body Transmit RF Coil
RF Receive Coil	Any Receive coil may be used
MR System (RF) Operating Modes or Constraints	Normal Operating Mode
Maximum Whole-Body SAR	2.0 W/kg (Normal Operating Mode)
Scan Duration	15 minutes of continuous RF (a sequence or back to back series/scan without breaks)
MR Image Artifact	The presence of Rhythmink MR Conditional/CT EEG Electrodes may produce an image artifact. Some manipulation of scan parameters may be needed to compensate for the artifact.

Remove extension cables [Fig. 1] before entering an MR environment. They are MR Unsafe.

Under the scan conditions described above, the MR Conditional/CT PressOn Electrode is expected to produce a maximum temperature rise of 2.0°C after 15 minutes of continuous scanning.

In non-clinical testing, the image artifact caused by the MR Conditional/CT PressOn Electrode extends less than 2 mm from the MR Conditional/CT PressOn Electrode when imaged with a gradient echo pulse sequence and a 3T MRI System.

The MR Conditional/CT PressOn Electrode, dual and multiple configuration [2 to 48 electrodes] have not been tested in simultaneous combination with other devices.

Artifact Information

MR image quality may be compromised if the area of interest is in the same area or relatively close to the position of the device. Therefore, it may be necessary to optimize MR imaging parameters for the presence of this device.

MR image artifacts can affect the device surrounding on each side from the device surface as follows:

Non-Clinical Artifact Testing at 3T	Spin Echo	Gradient Echo
Test object length	0.95 mm	1.81 mm
Test object diameter	1.56 mm	1.85 mm

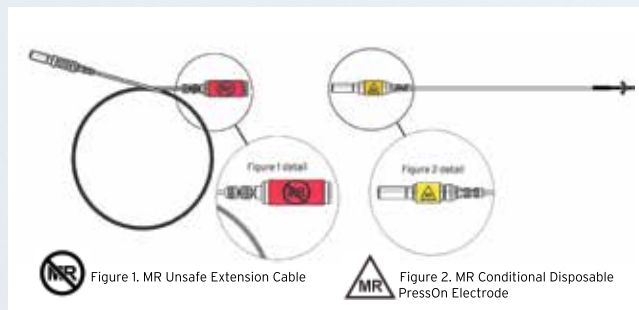

Application Styles

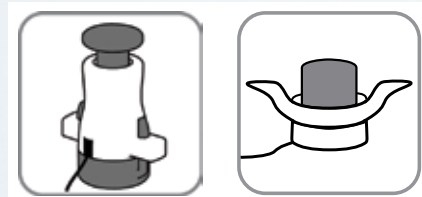

Please consult our most current product labeling and IFU documents for full product details.

MR Conditional/CT Individual Connectors Sticky Pad™ Electrodes

Intended Use

The Rhythmink MR Conditional Sticky Pad Electrode is intended for use with recording, monitoring, and stimulation equipment in the study of biopotentials such as Electroencephalograph (EEG), Surface Electromyography (EMG), or Nerve Conduction Evoked Potential Signals (EP). This device is non-sterile, single-use only, and may remain on the patient in a MRI environment under specific conditions.

Intended Applications

EEG [Electroencephalography], EP [Evoked Potentials], IONM [Intraoperative Neurophysiological Monitoring], ICU [Intensive Care Unit], NCS [Nerve Conduction Studies], LTM [Long Term Monitoring], PSG [Polysomnography] and Ambulatory.

Caution

Federal [USA] law restricts this device to sale by or on the order of a physician. Rhythmink International, LLC is not responsible for injury, infection or other damage resulting from the use or misuse of this product.

MR Conditional Sticky Pad Surface Electrodes are for professional use only and should only be used in compliance with accepted industry standards. The included extension cables are MR Unsafe (Fig 1). Remove all extension cables before entering a MR environment.

Instructions for Use

Select appropriate Sticky Pad electrode. Remove excess hair, oils and dirt. Prep application site, remove Mylar backing from electrode and place on application site. Apply pressure to center of electrode and move to edges. Remove all extension cables before entering a MR environment. When finished, remove by pulling directly on electrode, not the cable. Remove remaining hydrogel with clean, soapy water. This product is single-patient use only. Discard electrode after use.

MRI Safety Information

Non-clinical testing has demonstrated that the MR Conditional Sticky Pad Surface electrodes (Fig 2) are MR Conditional in configurations of 2 to 48 electrodes. These electrodes can safely remain on the patient during a MR scan meeting the following conditions:

Parameter	Condition of Use/Information
Device Name	Rhythmink MR Conditional Sticky Pad Electrode
Static Magnetic Field Strength (Bo)	0.2T, 0.5 T, 1T, 1.5T, 3T
Static Magnetic Field Strength (Bo) Orientation	Horizontal, cylindrical bore
Maximum Spatial Field Gradient	250 T/m (25,000 gauss/cm)
RF Polarization	Circular Polarized (CP)
RF Transmit Coil	Integrated Whole Body Transmit RF Coil
RF Receive Coil	Any Receive coil may be used
MR System (RF) Operating Modes or Constraints	Normal Operating Mode
Maximum Whole-Body SAR	2.0 W/kg (Normal Operating Mode)
Scan Duration	15 minutes of continuous RF (a sequence or back to back series/scan without breaks)
MR Image Artifact	The presence of Rhythmink MR Conditional/CT EEG Electrodes may produce an image artifact. Some manipulation of scan parameters may be needed to compensate for the artifact.

Remove extension cables [Fig. 1] before entering an MR environment. They are MR Unsafe.

Under the scan conditions defined above, the MR Conditional Sticky Pad electrodes are expected to produce a maximum temperature rise of 3.1°C or less after 15 minutes of continuous scanning (i.e., per pulse sequence) when aligned parallel to the static magnetic field.

In non-clinical testing, the image artifact caused by device extends less than 3.55mm from the MR Conditional Sticky Pad electrode when imaged with a gradient echo pulse sequence and a 3.0 Tesla MRI system.

The MR Conditional Sticky Pad Electrodes have not been tested in simultaneous combination with other devices.

Artifact Information

MR Image quality may be compromised if the area of interest is in the same area or relatively close to the position of the device. Therefore, it may be necessary to optimize MR imaging parameters for the presence of this device. MR image artifacts can affect the device surrounding on each side from the device surface as follows:

Non-Clinical Artifact Testing at 3T	Spin Echo	Gradient Echo
Test object length	1.78 mm ²	.99 mm
Test object diameter	1.77 mm ³	.55 mm

The included extension cables are MR Unsafe. Remove all extension cables before entering a MR environment.

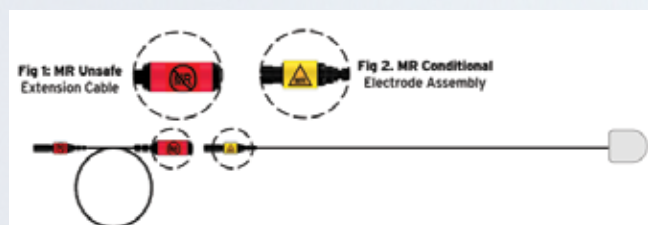

Please consult our most current product labeling and IFU documents for full product details.



MRI FAQ's for RhythmLink's MR Conditional EEG Electrodes

RhythmLink's Instructions for Use (IFU) state that the "electrodes can safely remain on a patient for 15 minutes of continuous scanning." Does this mean that the whole MRI can only last 15 minutes?

According to the FDA guidance document, a device that is demonstrated to heat up less than 4°C in 15 minutes in Normal Operating Mode can be scanned for 1 hour in Normal Operating Mode without a cooling period. The 15-minute limit described in the IFU only applies to a single continuous pulse sequence and not the total time that the patient is in the scanner or department. An MRI pulse sequence is a programmed set of changing magnetic gradients. Each sequence will have a number of parameters, and multiple sequences are grouped together into an MRI protocol. A patient's protocol can vary in length (i.e. 60 minutes) but unless a single pulse sequence lasts longer than 15 minutes, the electrodes can remain applied to the patient as long as necessary for completion of the full procedure. When using RhythmLink's MR Conditional Electrodes, it is essential that the Specific Absorption Rate [SAR] and duration of each pulse sequence be maintained at or below 2 W/kg as indicated in the IFU.

What if a single pulse sequence lasts longer than 15 minutes?

As mentioned above, most protocols include multiple pulse sequences with cool-down breaks in between each sequence but if, for some reason, a pulse sequence longer than 15 minutes is required, the machine must be run at a lower SAR. The new, lower SAR must be recalculated according to the hospital's own validated protocols. The method or combination of methods used to mitigate the temperature rise in the electrodes needs to be chosen by the hospital, and the lengths of the scan/sequence durations and/or the lengths of the breaks between pulse sequences must be determined using the hospital's own validated protocols.

Can a head coil be used with RhythmLink MR Conditional Electrodes?

RhythmLink's testing was performed using body coils because they are, in this application, most likely to cause the highest amount of RF-induced heating; they are the worst-case coil. A head coil can be used as long as the SAR, pulse sequence duration, field strength, and field gradient limits shown in the IFU are observed.

Can I use a phased array coil?

The conditions for use defined in the IFU are specifically for the transmitting coil. Phased array coils are typically used as receiving coils, and the conditions for use are valid regardless of which type of receiving coil is used.

For questions not answered here, please contact your sales representative or our team at MRSafety@rhythmink.com